

PROFILE 1.2E-M-HC

Fresh Air Appliance (FAA/ERV)

Product #: 499514

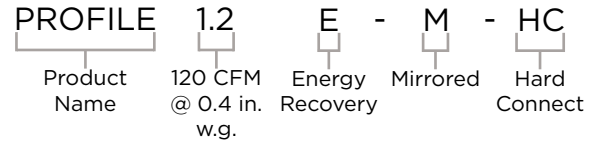

With the warm supply and return air on the left-hand side, the PROFILE 1.2E-M-HC gives building designers and contractors a viable solution for mirrored floor plans.

The PROFILE 1.2E-M-HC brings a continuous supply of fresh air into the premises while exhausting an equal amount of contaminated air out. As such, the energy recovery core transfers both heat and moisture from the outgoing exhaust air to the incoming fresh air, reducing the energy required to condition it.

Features

- Hard-connect system, no power cord provided
- Warm supply and return air on the left-hand side
- Compact design
- No drain required
- Easy to install on ceiling or wall with mounting bracket included
- Energy recovery core
- Electrostatic filters (washable)
- Removable screw terminal for easy connection with external access
- Multiple speed operation
- Lightweight

Optional Controls

- STS 2.0 (461580) – Programmable touch screen wall control
- EHC 2.5 (415518) – Electronic multi-function dehumidistat
- EHC 2.0 (415520) – Multi-function controller
- T4 (415519) – Wired digital timer 20/40/60 minutes
- T5 (463915) – Pushbutton timer 20/40/60 minutes
- RD-1 (463020) – Dehumidistat

Specifications

- Duct size – 5 in. (125 mm) round
- Voltage/Phase – 120/1
- Rated power – 120 W
- Running amperage – 1.0 A
- CSA rated amperage – 1.4 A
- MCA/MOP – 15 A
- Average airflow – 127 cfm (60 L/s) @ 0.4 in. wg (100Pa)
- Weight – 34 lbs (15 kg) including core

Fans

Two (2) factory-balanced fans with backward curved blades. Motors come with permanently lubricated, sealed ball-bearings to guarantee long life and maintenance-free operation.

Energy Recovery Core

Energy recovery core made from water vapor transport durable polymer membrane that is highly permeable to humidity. The ERV core is freeze tolerant, water washable, and is resistant to mold and bacteria. Core dimensions are 12 in. x 12 in. (305 x 305 mm) with a 8.15 in. (207 mm) depth.

Frost Prevention

A preset frost prevention sequence is activated at an outdoor air temperature of 14°F (-10°C) and lower. During the frost prevention sequence, the supply blower shuts down and the exhaust blower switches into high speed to maximize the effectiveness of the frost prevention strategy. The appliance then returns to normal operation, and continues the cycle.

Serviceability

Core, filters, fans and electronic panel can be accessed easily. Core conveniently slides out with only 8.5 in. (216 mm) clearance.

Duct Connections

5 in. (125 mm) round metal duct connections with rubberized seal.

Case

22 gauge G90 galvanized corrosion resistant steel case (pre-painted door).

Insulation

Insulated with 3/4 in. (20 mm) high density expanded polystyrene.

Filters

Two (2), UL900 certified, washable electrostatic panel type air filters 11.3 in. (287 mm) x 8.15 in. (207 mm) x 0.125 in. (3 mm)

Installation

Appliance is typically hung by using ceiling bracket supplied with appliance. Optional chain kit available.

Limited Warranty

7 years on the motor, 5 years on the electrical components and the core.

Dimensions & Airflow

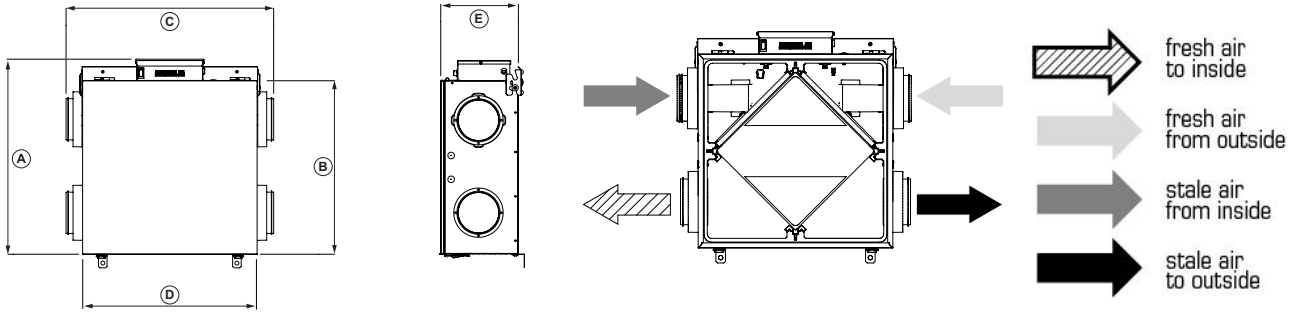

A		B		C		D		E	
in	mm	in	mm	in	mm	in	mm	in	mm
23 5/32	588	20 3/4	527	24 5/8	625	20 27/32	529	9 1/4	235

Clearances:
 8 1/2 in. (216 mm.) in front of the product for removal of core.
 2 3/8 in. (61 mm.) above the electrical box to do the wire connections.

Ventilation Performance

in.wg. (Pa)	0.1 (25)	0.2 (50)	0.3 (75)	0.4 (100)	0.5 (125)	0.6 (150)	0.7 (175)	0.8 (200)
	cfm (L/s)	cfm (L/s)	cfm (L/s)	cfm (L/s)	cfm (L/s)	cfm (L/s)	cfm (L/s)	cfm (L/s)
Net supply airflow	155 (73)	146 (69)	136 (64)	127 (60)	117 (55)	106 (50)	95 (45)	83 (39)
Gross supply airflow	159 (75)	150 (71)	140 (66)	129 (61)	119 (56)	108 (51)	97 (46)	87 (41)
Gross exhaust airflow	163 (77)	153 (72)	142 (67)	131 (62)	123 (58)	112 (53)	100 (47)	89 (42)

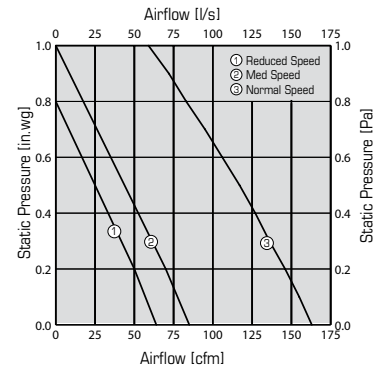

Energy performance

	Supply temperature		Net airflow		Consumed power	Fan efficacy	Sensible recovery efficiency	Adjusted sensible recovery efficiency	Latent recovery/moisture transfer
	°F	°C	cfm	L/s	W	cfm/W	%	%	%
Heating	32	0	51	24	55	0.9	74	81	76
	32	0	68	32	63	1.0	69	75	71
	32	0	131	62	104	1.2	64	69	60
	-13	-25	51	24	55	0.9	61	63	54
Cooling	Supply temperature		Net airflow		Consumed power	Fan efficacy	Total recovery efficiency	Adjusted Total recovery efficiency	Latent recovery/moisture transfer
	°F	°C	cfm	L/s	W	cfm/W	%	%	%
Cooling	95	35	51	24	55	0.9	64	68	68

Requirements and standards

- Complies with the UL 1812 requirements regulating the construction and installation of Heat Recovery Ventilators
- Complies with the CSA C22.2 no. 113 Standard applicable to ventilators
- Complies with the CSA F326 requirements regulating the installation of Heat Recovery Ventilators
- Technical data was obtained from published results of test relating to CSA C439 Standards
- HVI certified

Contacts

Submitted by: _____	Date: _____
Quantity: _____	Model: _____
Project #: _____	
Comments: _____	
Location: _____	
Architect: _____	
Engineer: _____	Contractor: _____

Distributed by: