

PREMIER 1.5E (PRS 1.5E)

Fresh Air Appliance (FAA/ERV)

Product #: 463922



Greentek's PRS is an Energy Recovery Ventilator designed for higher static pressure applications. The unit brings a continuous supply of fresh air into a home while exhausting an equal amount of contaminated air. The energy recovery core at the center of the unit transfers heat and moisture from incoming air to the outgoing air that was cooled and dried by the building's air conditioner.

Features

- Compact design
- Fans with backward curved blade
- Electrostatic filters (washable)
- ERV core transfers both heat and humidity
- Anti-microbial material
- Withstands freezing
- AHRI certified
- Removable screw terminal for easy connection with external access
- Lightweight 48 lbs (21Kg)
- Multiple speed operation

Optional Controls

- STS 2.0 (461580) Programmable touch screen wall control
- EHC 2.5 (415518) Electronic multi-function dehumidistat
- EHC 2.0 (415520) Multi-function controller
- T4 (415519) Wired digital timer 20/40/60 minutes
- T5 (463915) Pushbutton timer 20/40/60 minutes
- RD-1 (463020) Dehumidistat

Specifications

- Duct size – 6" (152 mm)
- Voltage/Phase – 120/1
- Power rated – 168 W
- Amp – 1.4 A
- Average airflow – 161 cfm (76 L/s)
@ 0.4" P_s (100Pa)

Fans

Two (2) factory-balanced fans with backward curved blades. Motors come with permanently lubricated, sealed ball-bearings to guarantee long life and maintenance-free operation.

Energy Recovery Core

Energy recovery core made from water vapor transport durable polymer membrane that is highly permeable to humidity. The ERV core is freeze tolerant and water washable. Core dimensions are 12" x 12" (305 x 305mm) with a 10" (254mm) depth.

Defrost

A preset defrost sequence is activated at an outdoor air temperature of 14°F (-10°C) and lower. During the defrost sequence, the supply blower shuts down & the exhaust blower switches into high speed to maximize the effectiveness of the defrost strategy. The unit then returns to normal operation, and continues cycle.

Serviceability

Core, filters, fans and drain pan can be easily accessed through latched door. Core conveniently slides out on our new easy glide core guides. 17" (432 mm) of clearance is recommended for removal of core.

Case

22 gauge galvanized steel corrosion resistant.

Insulation

Cabinet is fully insulated with 3/4" (19mm) high density expanded polystyrene.

Filters

Two (2) washable electrostatic panel type air filters 10" (254mm) x 11.9" (302mm) x 0.125" (93mm).

Controls

External three (3) position (Low/Stand By/Medium) rocker switch that will offer continuous ventilation. Greentek offers a variety of external controls. (see controls)

Installation

Unit is typically hung by using installation kit supplied with unit. Mounting chains inserted on hooks located on top four (4) corners of unit. An optional wall bracket is available.

Warranty

5 year on core, 7 year on motors, and 5 year on parts.

Dimensions & Airflow

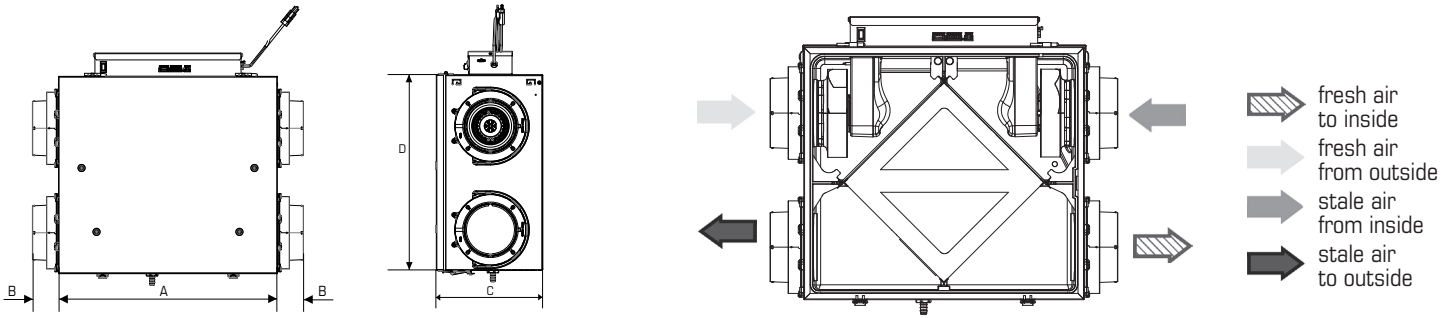

Model	A		B		C		D	
	in	mm	in	mm	in	mm	in	mm

PRS 1.5E 23 7/8 606 29 1/2 750 11 11/16 303 21 7/16 545

Clearance of 17" (432 mm) in front of the unit is recommended for removal of core. All units feature three foot plug-in power cord with 3-prong plug.

Ventilation Performance

in.wg. (Pa)	0.1 (25)	0.2 (50)	0.3 (75)	0.4 (100)	0.5 (125)	0.6 (150)	0.7 (175)	0.8 (200)
	cfm (L/s)	cfm (L/s)	cfm (L/s)	cfm (L/s)	cfm (L/s)	cfm (L/s)	cfm (L/s)	cfm (L/s)
Net supply airflow	201 (95)	189 (89)	174 (82)	161 (76)	146 (69)	131 (62)	117 (55)	104 (49)
Gross supply airflow	203 (96)	191 (90)	176 (83)	163 (77)	148 (70)	131 (62)	119 (56)	106 (50)
Gross exhaust airflow	201 (95)	186 (88)	172 (81)	159 (75)	144 (68)	131 (62)	117 (55)	104 (49)

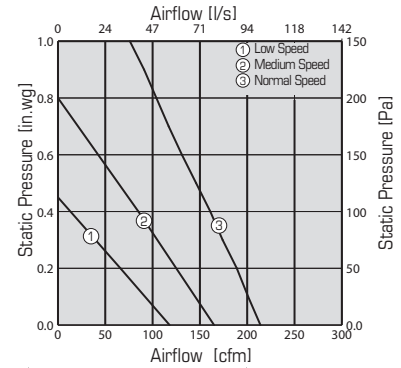

Energy performance

	Supply temperature		Net airflow		Consumed power	Sensible recovery efficiency	Adjusted sensible recovery efficiency	Latent recovery/moisture transfer
	°F	°C	cfm	L/s	W	%	%	%
Heating	32	0	64	30	52	75	81	58
	32	0	148	70	104	67	72	45
	-13	-25	64	30	53	60	62	47

	Supply temperature		Net airflow		Consumed power	Total recovery efficiency	Adjusted Total recovery efficiency	Latent recovery/moisture transfer
	°F	°C	cfm	L/s	W	%	%	%
Cooling	95	35	64	30	52	60	63	60
	95	35	146	69	106	55	58	50

Requirements and standards

- Complies with the UL 1812 requirements regulating the construction and installation of Heat Recovery Ventilators
- Complies with the CSA C22.2 no. 113 Standard applicable to ventilators
- Complies with the CSA F326 requirements regulating the installation of Heat Recovery Ventilators
- Energy Recovery Core is certified for mold and bacteria resistance
- Technical data was obtained from published results of test relating to CSA C439 Standards

Contacts

Submitted by: _____	Date: _____
Quantity: _____ Model: _____	Project #: _____
Comments: _____	
Location: _____	
Architect: _____	
Engineer: _____	Contractor: _____

Distributed by: